



## User Guide

### IOTWD Series

### Bus Air Conditioning Operating Panel

19011019  
A00

1

#### Preface

Thank you for purchasing the IOTWD series bus air conditioning operating panel developed and manufactured independently by Inovance. Its main features include:

- ◆ Anti-dazzle design
  - ◆ Multiple installation modes, meeting IP54 requirements
  - ◆ Optional remote network connection function
- 1) Real-time remote monitoring of the running status of the bus air conditioner
  - 2) Real-time bus positioning
  - 3) Timely alarms when faults occur
  - 4) Web page and app supported
  - 5) Remote upgrade of firmware programs
  - 6) Remote CV800 program upgrade and parameter modification when used with Inovance's CV800 series products

#### User Guide and Acquisition

Before using the product, read this user guide carefully to fully understand the features of the product and ensure safe use.

The information in this user guide is subject to change without notice. Please acquire the latest document version by the following means:

- ◆ Contact the distributor.
- ◆ Scan the QR code on the document cover.

## 1. Product Information

### Model number

IOT WD - 2 001 D

Mark	Product Type	IOT	Industrial IoT product	Mark	Power Supply	D	DC power supply
Mark	Product Category			Mark	Screen Type		
WD	Operating panel	001	LED screen				
Mark	IoT Function	043	4.3-inch LCD screen				
0	None						
2	2G IoT functions						

### Technical data

Item	Technical Data
Power	24 VDC (10 VDC to 32 VDC)
Power consumption	5 W
Operating current	Max. 400 mA
Faults and alarms	Display of Internet of Things (IoT) faults, CAN communication faults, and CV800 series drive faults
Ambient temperature	-25°C to +65°C
Storage temperature	-40°C to +70°C
Display	LED (red)
Display accuracy	Specified temperature displayed using two digits with an accuracy of 1°C Car temperature/Ambient temperature displayed using two digits with an accuracy of 1°C
Connector	Mini-fit plastic connector: Receptacle - 4.2 mm - 2*5P
IP rating	IP54
Overall dimensions	175 mm x 68 mm x 45.4 mm
Weight	180 g

### Keys on the operating panel

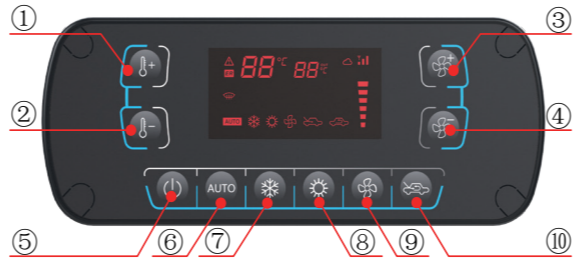

No.	Function	No.	Function
①	Temperature+	①+⑥	PTC
②	Temperature-	①+⑦	Defrosting/Defogging
③	Air flow+	①+⑧	Humidification
④	Air flow-	①+⑨	Drying
⑤	On/Off	①+⑩	Recirculation
⑥	Auto mode	①+③	Mode 2
⑦	Cooling mode	①+②	Disinfecting
⑧	Heating mode	③+②	CV800 query
⑨	Ventilation mode	②+④	Function setting
⑩	Fresh air on/off	②+⑩	Fault code query

### Description of icons on the operating panel

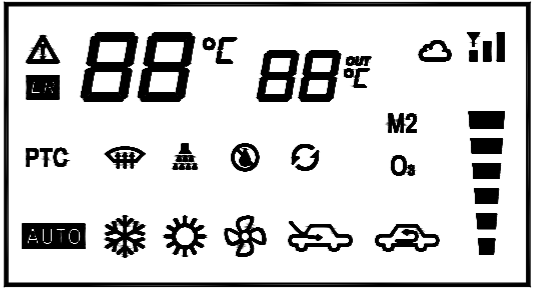

No.	Icon	Function	No.	Icon	Function
1	88°C	Car temperature/Set temperature	2	88°C	Ambient temperature
3	⚠	Alarm	4	ER	Fault display
5	☁	Remote connection status	6	📶	2G signal intensity
7	AUTO	Auto mode	8	❄	Cooling mode
9	☀	Heating mode	10	🌀	Ventilation mode
11	🚗	Fresh air	12	🚗	Internal recycle
13	PTC	PTC	14	👁	Defrosting/Defogging
15	💧	Humidification	16	🕒	Drying
17	🔄	Recirculation	18	O <sub>3</sub>	Disinfecting
19	M2	Mode 2	20	📶	Air flow

## 2. Installation and Wiring

### Installation dimensions

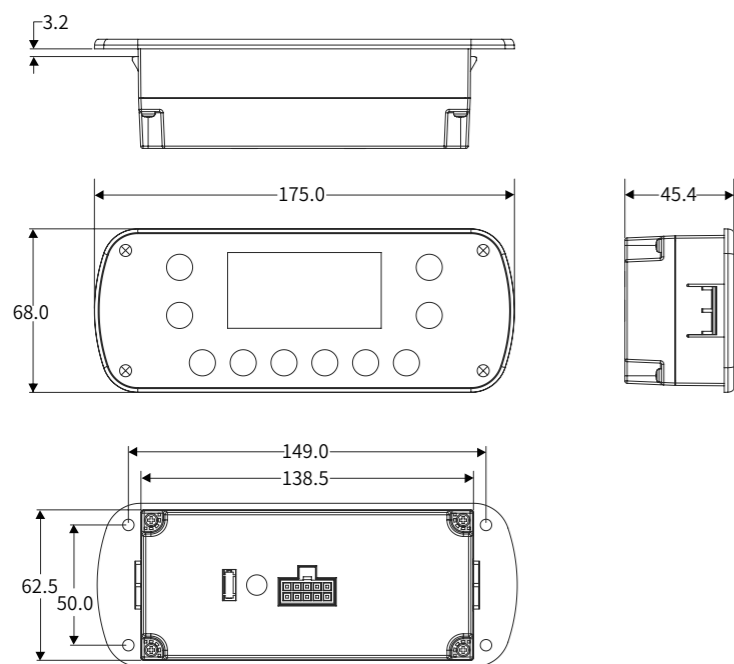

### Installation methods

The IOTWD series bus air conditioning operating panel can be installed using snap fits or self-tapping screws.

#### Installation using snap fits

Put the operating panel on the reserved mounting hole of the bus control console plate and push it until you hear clicks.

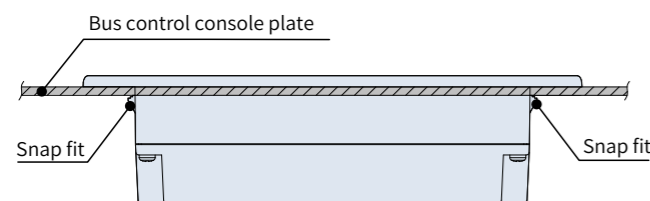

Installation of the bus air conditioning operating panel

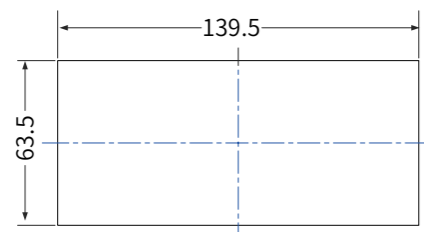

Dimensions of the reserved mounting hole on the bus control console plate

#### Installation using self-tapping screws

Insert and tighten M4 self-tapping screws through positions marked by ⊗ on the operating panel to install it on the bus control console plate.

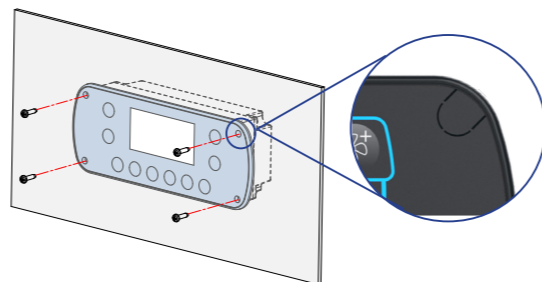

Note: For details about the dimensions of the mounting hole, see "[Installation dimensions](#)". You can select the length of self-tapping screws based on actual situations. The dotted lines in the preceding figure indicate the parts of the operating panel behind the bus control console plate.

### Wiring

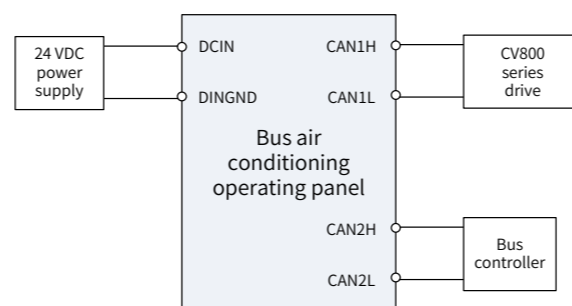

### Terminal description

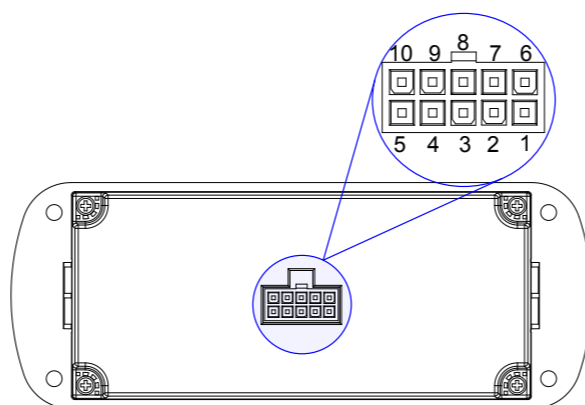

No.	Name	Description	No.	Name	Description
1	DCIN	24 V DC power input	6	DINGND	24 V DC power input (negative)
2	X-0	Common DI	7	X-GND	DI (negative)
3	GND	System grounding cable	8	CAN2H	CAN-H connected with ECU, without isolation
4	CGND	Isolation ground, CAN1 grounding cable	9	CAN2L	CAN-L connected with ECU, without isolation
5	CAN1H	CAN-H connected with CV800, with isolation	10	CAN1L	CAN-L connected with CV800, without isolation

## 3. Typical Application

The following figure shows the typical application of the IOTWD series bus air conditioning operating panel in the bus air conditioning industry.

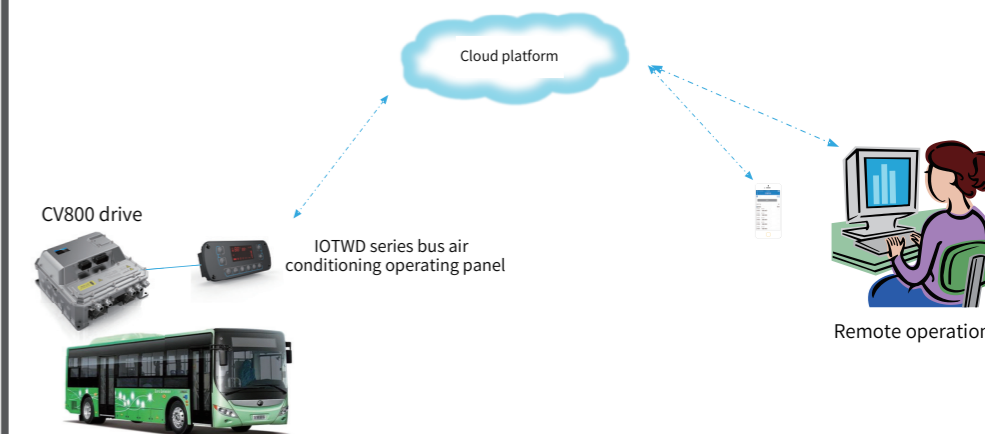

NOTE

- ◆ For IOTWD-0001D without IoT functions, the running status of the bus air conditioner can be monitored only by IOTWD-0001D.
- ◆ For IOTWD-2001D with IoT functions, the running status of the bus air conditioner can be monitored by both IOTWD-2001D and a computer/mobile phone in real time.

## INOVANCE Warranty Agreement

- 1) Inovance provides an 18-month free warranty to the equipment itself from the date of manufacturing for the failure or damage under normal use conditions.
- 2) Within the warranty period, maintenance will be charged for the damage caused by the following reasons:
  - a. Improper use or repair/modification without prior permission
  - b. Fire, flood, abnormal voltage, natural disasters, and secondary disasters
  - c. Hardware damage caused by dropping or transportation after procurement
  - d. Operations not following the user instructions
  - e. Damage out of the equipment (for example, external device factors)
- 3) The maintenance fee is charged according to the latest Maintenance Price List of Inovance.
- 4) If there is any problem during the service, contact Inovance's agent or Inovance directly.
- 5) Inovance reserves the rights for the explanation of this agreement.

Suzhou Inovance Technology Co., Ltd.

Address: No.16, Youxiang Road, Yuexi Town, Wuzhong District, Suzhou 215104, P.R. China

Website: <http://www.inovance.com>